

# E.B.Models Slotted Post Signals System 3

## CONSTRUCTING SUITABLE SIGNAL POSTS

This is a revised version of the Sheet 3 that was originally issued, when the range of slotted post signals was first introduced back in 2003.

1. From the new range of tapered posts, select the size that is just larger than the height of post you require.

Construction is simple as both halves are folded to exactly 90degrees in a pair of folding bars, and then located together by tab and open slot, and simply soldered along the join lies, and cleaned up with a file.

In the case of junction brackets, you will need to know what sizes doll posts were. It seems that the large "base post" that supported symmetrical junction brackets were large, but with little taper, so use K&S square tube for those. Again, YOU MUST USE PHOTOS.

In some cases, 'nearest may have to do' but err on oversize. Cut matched posts, in the case of bracket dolls.

With this new method of construction, the dimensions of the taper will automatically be maintained and all four sides will be maintained correctly as guesswork is elimintaed.

Ensure that any necessary shortening of posts is kept as quare to the 'centre-line axis' as possible. If it has to be from the bottom of the post remember that the tabs will be lost.

2. Use short lengths of 1.5mm brass rod or round tube to fit snugly into the top of the square post. Cut a very short length to act a location aid for the slot boxes to be attached to.

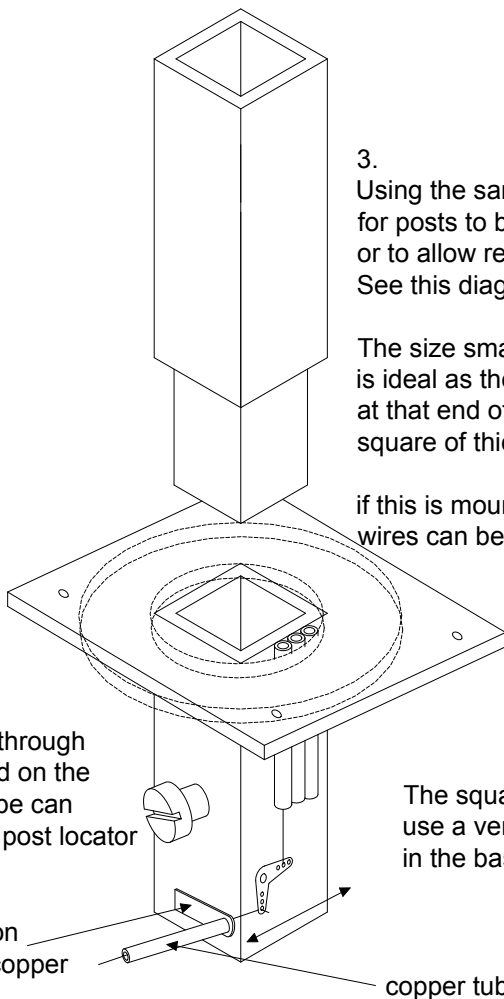
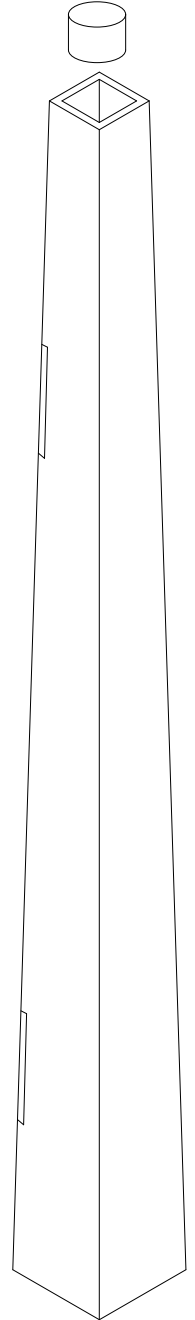

3. Using the same interlocking tubes, you can arrange for posts to be fitted very solidly - either for permanent or to allow removal for transporting. See this diagram for the way these tubes can be used:-

The size smaller than the lower end of the signal post is ideal as the locator, and the same size as was used at that end of the post can be soldered underneath a square of thick brass - to allow a baseboard fixing.

if this is mounted over a drilled hole, control tubes and wires can be passed down beside the post locator.

A hole is drilled in the area of the baseboard beneath the signal's location. It is shown here to indicate how the control wire tubes would fit beside the square tube.

The square base suits this arrangement - but you can use a very shallow drill to slightly recess the round base in the baseboard.

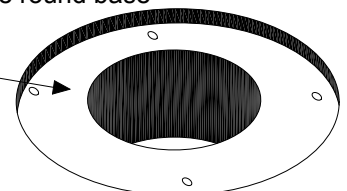

brass solder-on lug to attach copper tube

copper tube for wire-in-tube signal control

